



ISO 9001:2015 Registered
AS9100D May 2018 Registration

**“Where Today’s Machining Challenges
Become Tomorrow’s Technology”**

Our Eye’s On Quality



SENSOR INDUSTRY PARTS

Multi Hybrid & Swiss

We’ve been machining Sensor Components since 1990; Our niche is in machining difficult to source sensor components made from glass to metal sealing alloys such as Inconel, kovar, stainless steel, monel and other aerospace alloys.

We would like to help you source your difficult to machine sensor components.

Our customers have found us to be responsive with attention to details and **“process friendly”** features critical to a quality seal. We also maintain part tolerance histories to insure you can use the same sealing glass with every delivery from REHTEK.

Niche Machining Parts

Bodies	Load Cells
Headers	Sensor
Feed-Thru’s	Connectors

Some of the Materials We Machine

Kovar	Inconel
Alloy 42	Stainless
Invar	Titanium

Our Multi-Task Machining & Drilling

OD: .005” – 5.00”	Length up to 18”
ID: Bore .030”	Drilled Holes .005 & up
Taper Reaming	Sharp and Burr Free

REHTEK Machine Co.
135 Monroe Street
Passaic, NJ 07055

Tel 973-365-2101
Fax 973-365-2174
sales@rehtek.com

Cage Code: 58RB4

DUNS#:602829616

NAICS: 332710, 332721, 325920, 332994



Rehtek's exclusive pro-tek® Process optimizes every aspect of production by collaborating with Engineering to reduce cost and add greater value to your part.

We partner our "machining expertise" with "engineering" to pro-tek your parts



Header Sandbasted & Hermetic Seal Surface

With Critical to Quality Features (CTQ)

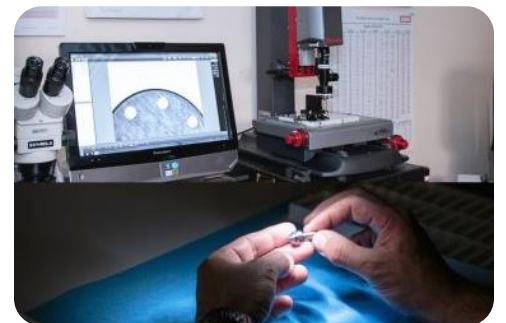
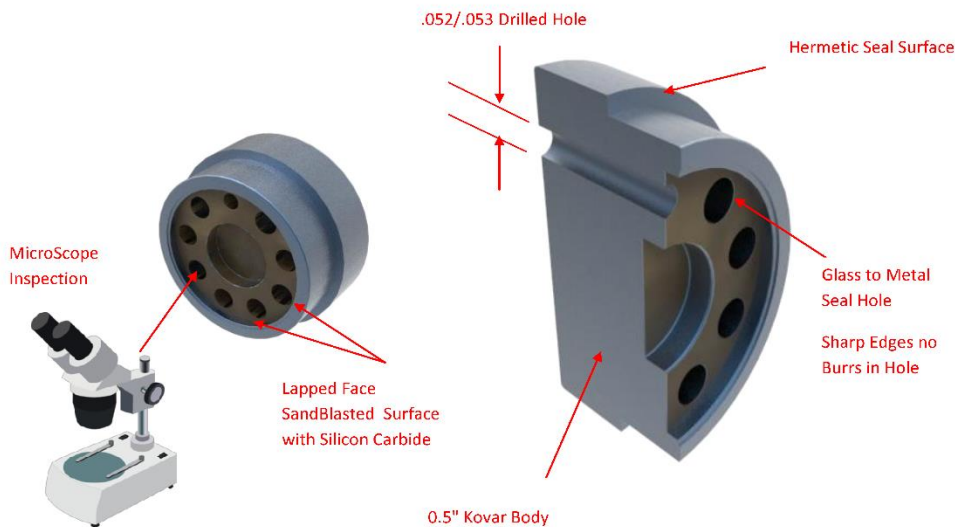

- Kovar Body
- CNC Hybrid Turned Blank
- CNC Gang Drilled
- Deburred
- Sandblasted
- Deburred With Microscope
- 100% Inspection of CTQ

www.rehtek.com